

Remote Controlled Monitor

The Tornado RC is very compact, yet it has a large 2-¼ inch waterway, capable of flowing up to 500 gpm, making it the ideal bumper turret. Waterway with turning vane has only 19 psi (1.3 bar) friction loss at 500 gpm (1900 l/min). Elevation range is 90° above horizontal to 45° below. Field changeable elevation travel stops at 45° above and 20° below horizontal. Horizontal travel is 370° (185° either side of a center position). Field changeable horizontal travel stops to give 180° (90° either side of a center position). Designed for 12 VDC or 24 VDC operation, selection is automatic. The Tornado RC comes with a control panel on the monitor for horizontal rotation, elevation, nozzle pattern, programmable PARK and Oscillate. See page 110-111 for additional control stations. The motor control circuits use position encoders and current limiting to protect the drive train at the ends of travel. Unit has waterproof factory installed plug on power wire for easy removal or reinstallation. Knobs for manual override are provided on the horizontal rotation and elevation drive. Electric drives and control box are waterproof. Main waterway made from hardcoat anodized ANSI 356-T6 aluminum. Silver powdercoat finish inside and out. Various inlets are available. Quick connect inlets and outlets allows for quick removal of the Tornado for installations such as bumper mounting, where the monitor must be removed to tilt the cab of the truck. RC Monitor delivered with wireless antenna installed. For wireless operation, purchase wireless operator station package on page 110.

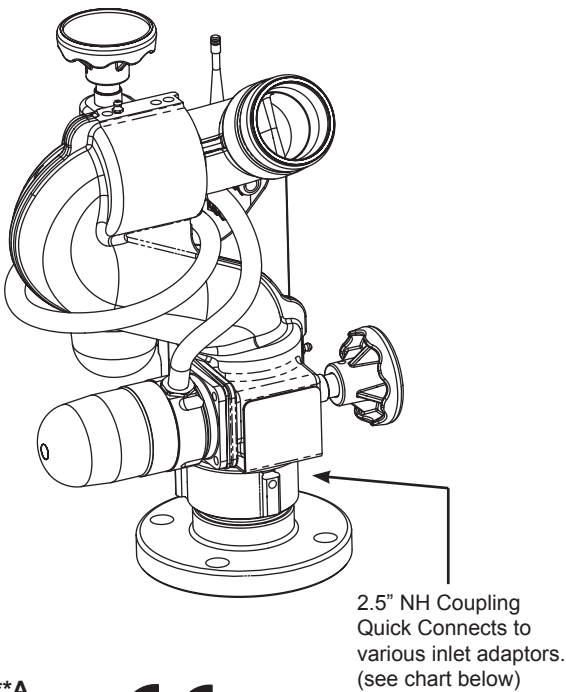

Y2-E**A
\$7250.00
25 lb. (11.4kg)

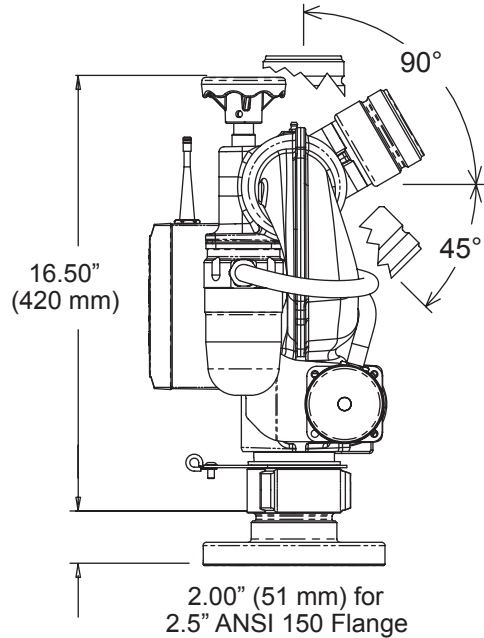
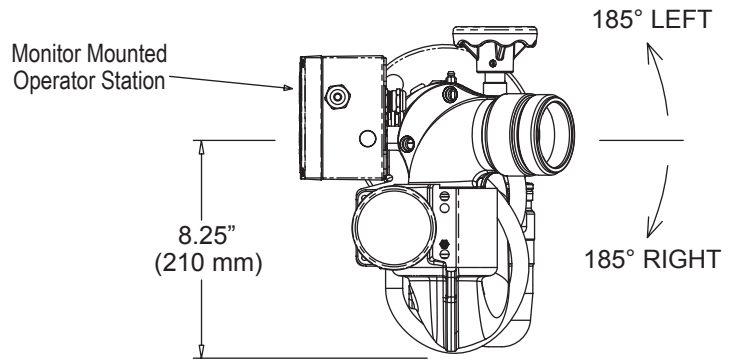

See pages 58 and 70 for ER nozzle choices

When ordering a Tornado RC monitor, choose one option from each category. Example: Y2-E61A is an electric monitor with 2.5" ANSI 150 flange inlet and 2.5" NH male threaded exit. For assistance in ordering, please call 1-800-348-2686 and speak to an RC monitor specialist.

Y2-E

Y2-E		A
Inlet	Outlet	
1) 2.5"-7.5 NH Female [§]	1) 2.5"-7.5 NH Male	
2) 2.5"-11 BSP Female	2) 2.5"-11 BSP Male	
3) 2.0"-11 BSP Female	3) 1.5"-11 BSP Male	
5) DN80, PN16	4) 1.5"-9 NH Male	
6) 2.5" ANSI 150	8) Special 1.5"	
7) 2.5"-8 NPT Female	9) Special 2.5"	
8) 2.0"-11.5 NPT Female	*Code-RLF fits	
9) 3.0"-8 NPT Female	Extend-A-Gun RC3	
L) TFT Code-RLF*	§No inlet adapter	